

1. Poly-Pak Removal

- 1.1 Insert a bolt into the bottom of the piston and place in a vise as shown.
- 1.2 Take a screw driver and insert it under the Bottom edge and pry the polypak out of the groove. **Be careful not to score the sealing area of the groove (See illustration).** Hold the polypak 90 deg. relative to the placement of the screw driver and work the polypak out of the groove.

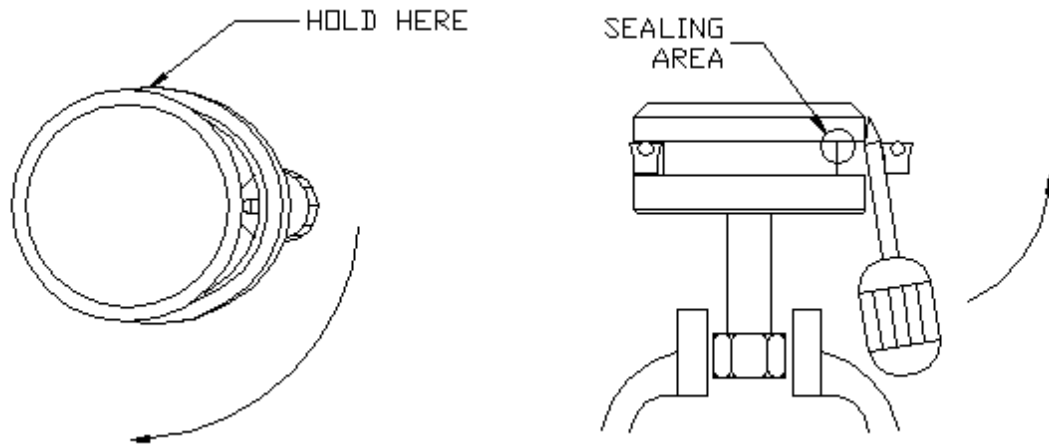

- 1.3 Hint: if the polypak is warm it will be easier to remove it. Place it in the sun or heat it with a hair dryer but don't get it too hot or you will warp the piston.
- 1.4 Check the piston for nicks and burrs on the edges and polish any scratches that might be in the sealing area with some emery paper.

2. Poly-Pak Installation

- 2.1 With the piston in the vise, place polypak into the groove and start working it onto the piston as shown by arrow #1. Before removing the screw driver, bring it back to the original position as shown by arrow #2. This should prevent the polypak from becoming twisted which would prevent it from sealing correctly. It may be easier if the polypak is warm. Place it in the sun or heat it with a hair dryer but don't get it too hot or you will warp the polypak.
- 2.2 Apply some assembly lubricant to the polypak before installation. (white lithium or hydraulic oil). Never install a non-lubricated polypak. Be certain that the "O" ring does not come out of the polypak.

