

The instructions below will show step by step how to re-install your top jaw.

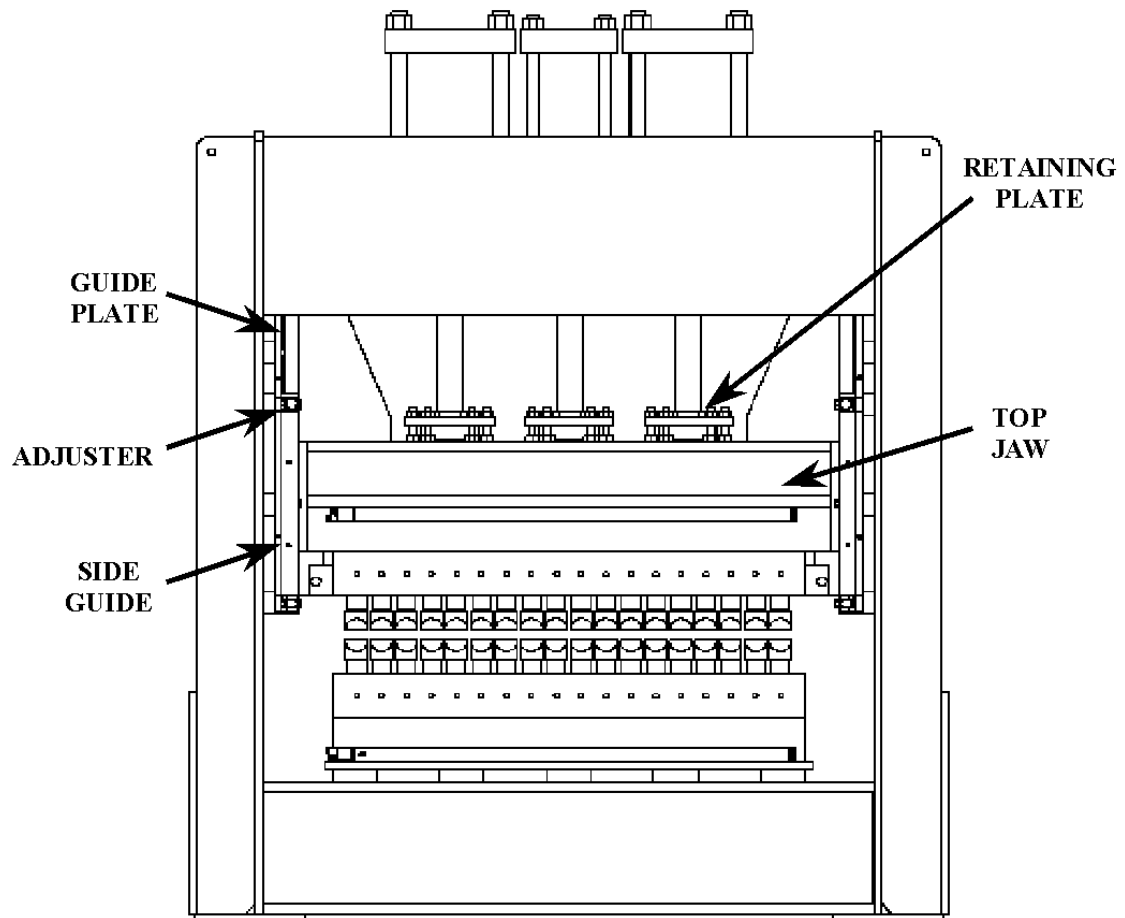

FIGURE 1

1. Wipe excessive grease off from the guides. A thin film left on the guides is ok.
2. Raise the top cylinder rods all of the way up to get them out of the way.
3. Mount a left and right side guide to stop the top jaw in position while putting it into the machine. They should both be on the front side of the machine if loading the top jaw from the backside.
4. Load the top jaw. And position it just above the bottom jaw. Mount the other two side guides to hold the jaw in position. Use the Side Guide Adjusters to move the jaw back and forth to get it into position.

5. Inspect the position of the top jaw. It needs to be true to the bottom jaw and centered under the upper hydraulic cylinder(s). Drop the cylinder rods and mount them loosely with the hold down plates and nuts.
 - The rod foot needs to be centered within the hold down plate. See figure 2.
 - The top teeth should be directly aligned above the bottom teeth. It may be helpful to take a mirror and look down the length of the teeth to verify that they are in line.

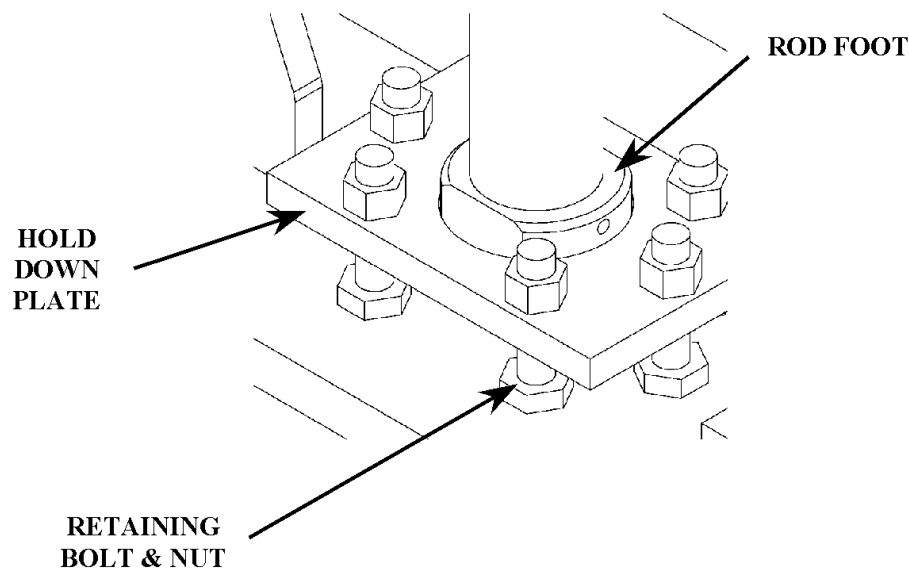

FIGURE 2 – retaining plate assembly

6. In most cases the jaw will naturally seek the correct alignment and so the objective is to not move the top jaw while tightening the side guides. If the top jaw is out of alignment, then take a measurement of how much so that it can be moved back into position with the guide adjusters later.
7. The retaining nuts may appear to be loose. Do not over tighten the nuts on the retaining bolts shown in figure 2. There may appear to be a gap between the rod foot and the top jaw beam. This is natural. Only the cylinder shaft should be pushing against the top jaw, not the rod foot. The system is designed to allow the rod foot to adjust to any misalignment with the top jaw.

8. Tighten the 5/8" guide plate bolts starting from the top and working down. When you reach the side guides slide them in until they are touching the top jaw guides and are flush. Tighten the 5/8" bolts.
9. Loosen the jam nut and turn the square head keeper bolt clockwise to tighten the side guide. DO NOT OVERTIGHTEN. 10 FT-LBS MAXIMUM. Check to be certain that the teeth are still aligned top and bottom and that the rod foot is still centered in the hold down plate. Tighten the jam nut.
10. Repeat step 6 on the remaining guide plate and side guides.
11. Grease the guides prior to using the machine.